

**Cost Management  
The Workforce  
Residue Opportunities**

**Laurie Gardner**

# Direct / Indirect Costs

## **Direct Costs**

- Resource
- Labour Costs
- Packing & Strapping
- Timber Treatment
- Power & Fuel
- R & M
- Saws and Knives

## **Indirect costs**

- Labour-On-Costs
- Replacement P & E Costs
- Interest on Stock
- Share of Admin Costs
- Insurance
- Staff Training
- Rates & Charges
- Licences
- Safety Expenses
- Workers Compensation

# Sales / Admin Costs

## **Sales**

- Advertising
- Commission
- Printing and Stationary
- Vehicle expenses

## **Administration**

- Bank charges and interest
- FBT
- Rates
- Rent
- Telephone / postage
- P&S
- Legal Fees
- Income tax

**A discount on the selling price of 5% will require an increase of sales by 20% to achieve the same bottom line result.**

# The Workforce

- People Skills
- Wages & Incentives
- Training
- Team Worksite & Motivation

# Residue

- Chips
- Sawdust
- Biomass

**Sawing**

**Owen Woodford**

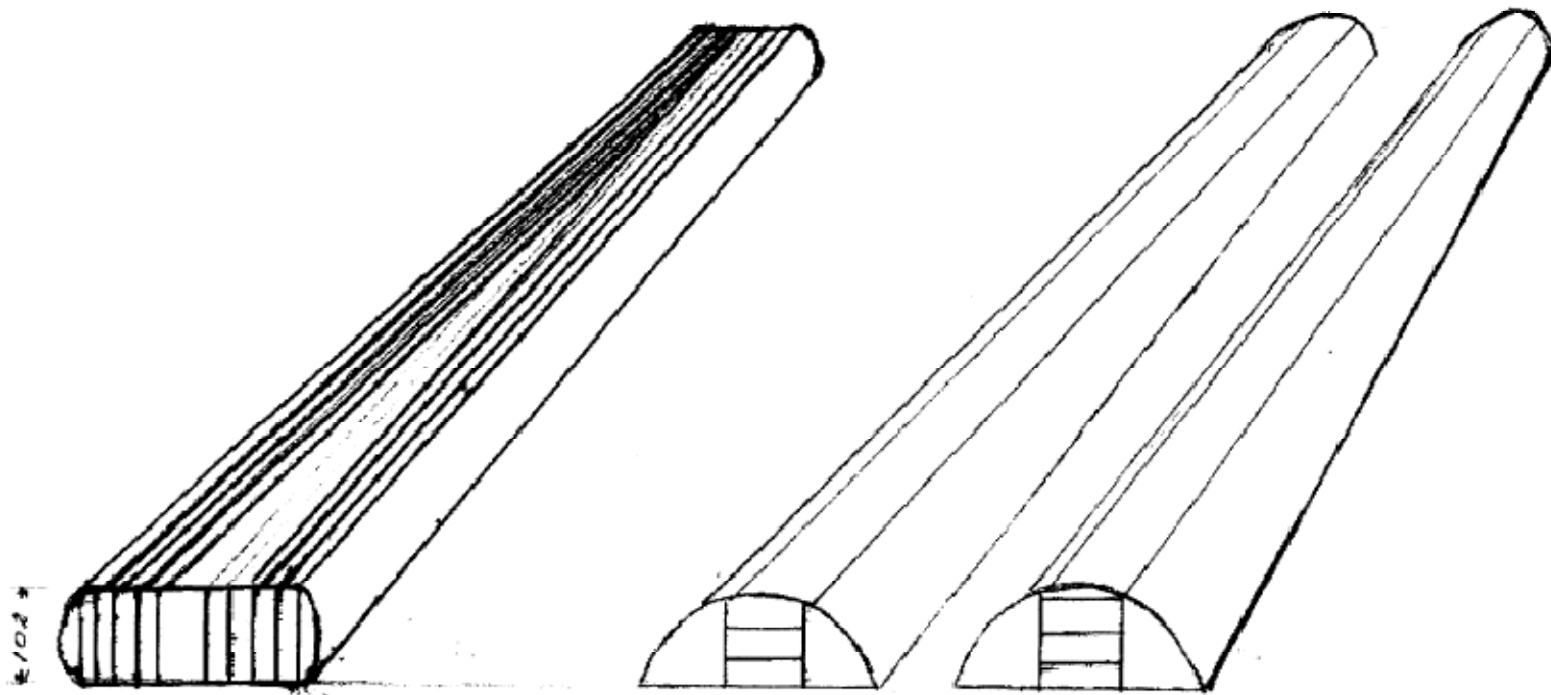

SMALL LOG PREFERRED SAWING PATTERN

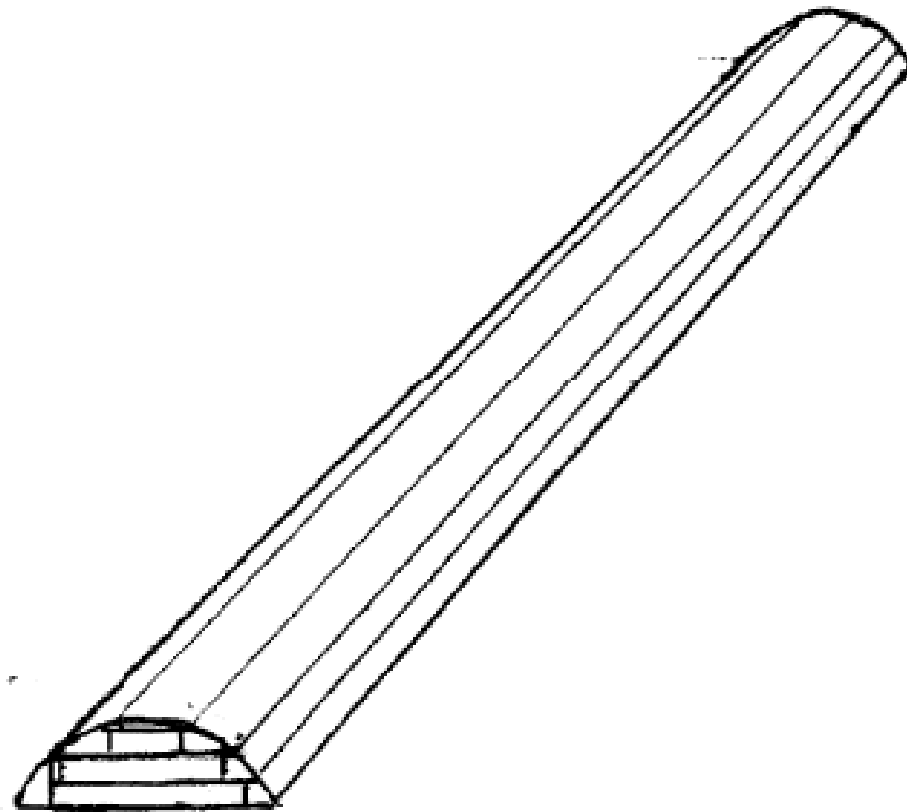

WIDE BOARD FLITCH CUTTING PATTERN.



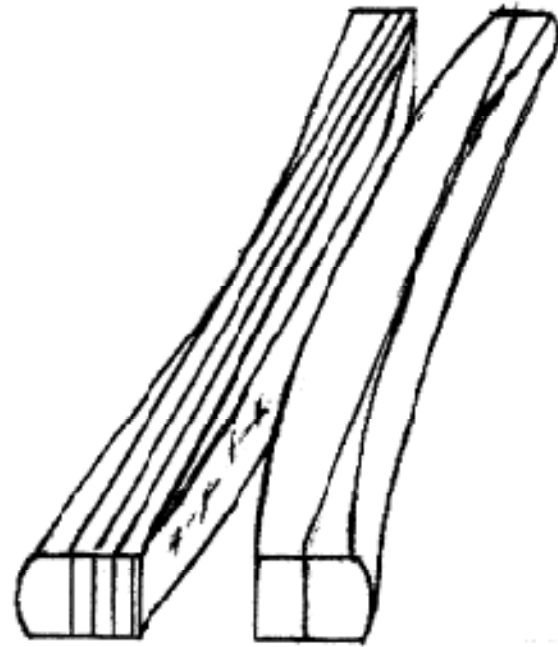
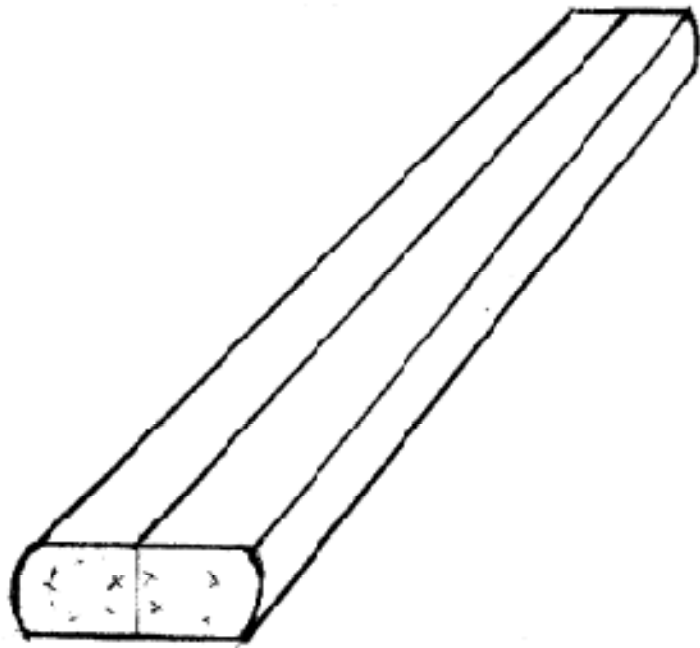

Don't Pop The Cant / Flip It.

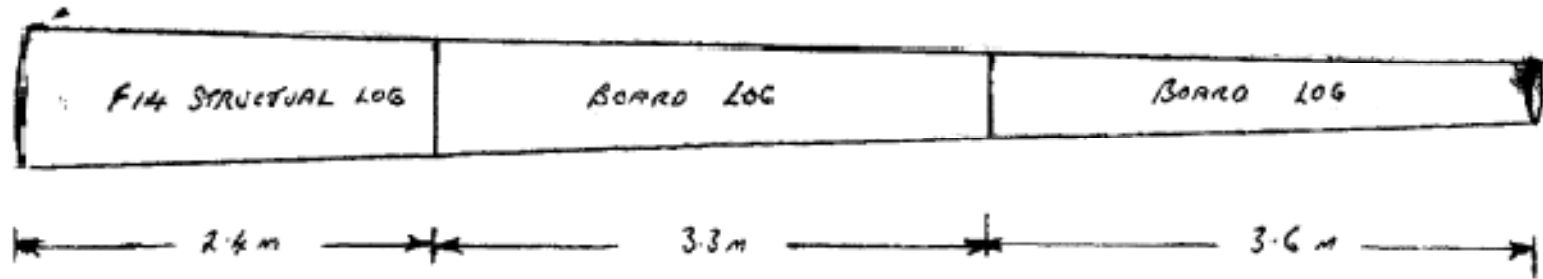
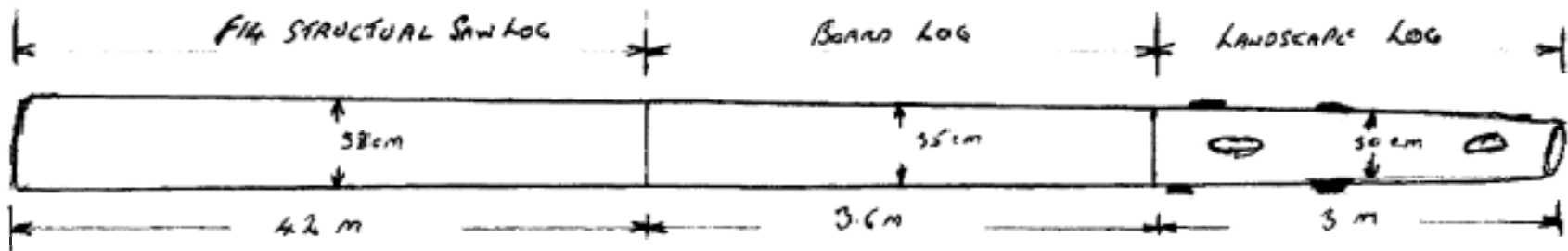
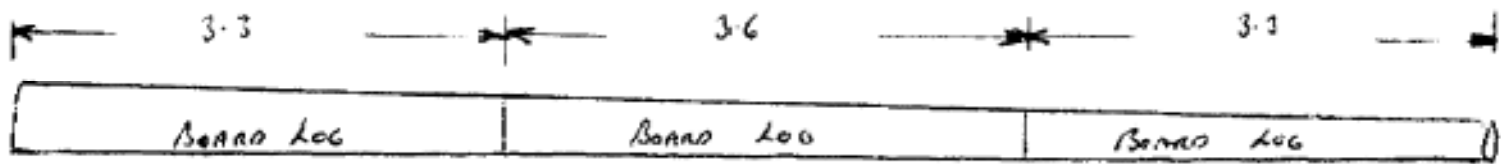

MERCHANDISE LOGS FROM TRUCK.

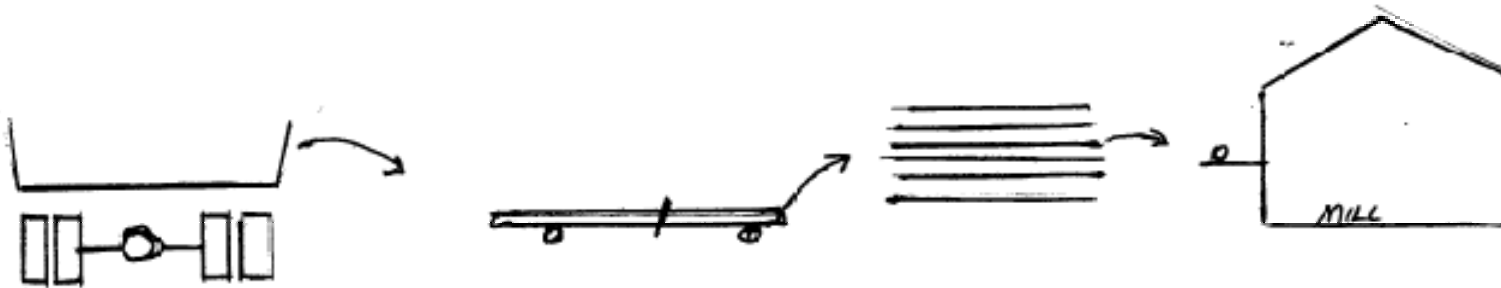
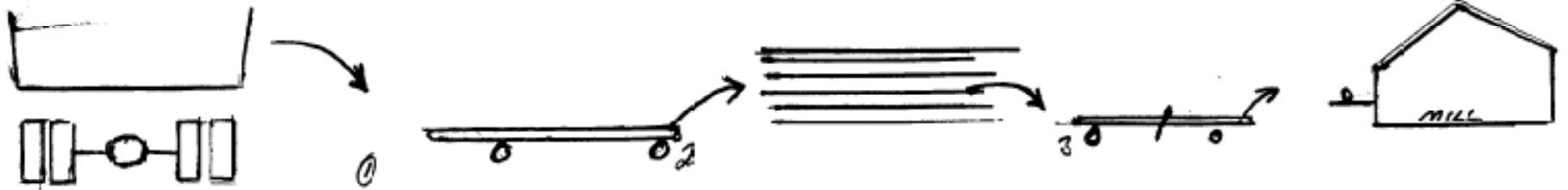

REDUCE HANDLING

KNOW WHAT IS IN STOCK

LOG LENGTH TELLS WHAT IS REQUIRED

EASY TO QUOTE ON AVAILABILITY

EASY TO BOOK EASY TO STOCK TAKE